



PL10

PL10 is a smart lock with embedded fingerprint recognition technology. It is DIY design, which can replace knob lock easily and quickly.

Features

- With the new generation fingerprint recognition algorithm
- Rugged, sleek and compact design
- American standard single latch for easy replacement and installation
- Independent clutch motor design under patent protection
- Idle handle design to prevent from forcible entry
- Registration data are stored even if there is power loss
- Handle, latch and strike is reversible design for all door open direction
- Infrared sensor–Touch to open
- Emergency key override (concealed)
- LED indicator and inbuilt buzzer
- External terminals to draw back-up power from a 9V battery
- Low battery warning
- Normal Open mode
- Easy to program and easy to use
- Easy to install–no wiring required
- 3 user groups - Admin, Normal User and Temporary User
- Backset is 60 mm or 70mm (adjustable)

Specifications

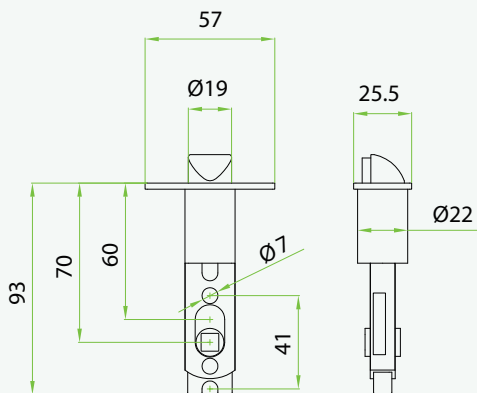

Material	Rugged ABS
User Capacity	Admin -10 Normal User - 60 Temporary User - 20
Operating Temperature	0°C - 45°C
Power Supply	4 xAA Alkaline Battery
Backup Unlocking Way	Mechanical Key & 9V Battery
Door Thickness	30-38 mm (optional) 39-46 mm (standard) 47-54 mm (standard) 55-60 mm (optional)
Dimensions	Front - 69(W)×155(L)×35(D) mm Back - 69(W)×155(L)×25(D) mm

ZKTeco South Africa

Tel: +27 12 259 1047 E-mail: sales@zkteco.co.za www.zkteco.co.za